

# HYPERION EOS0720iNET Layout & Sync Network Setup

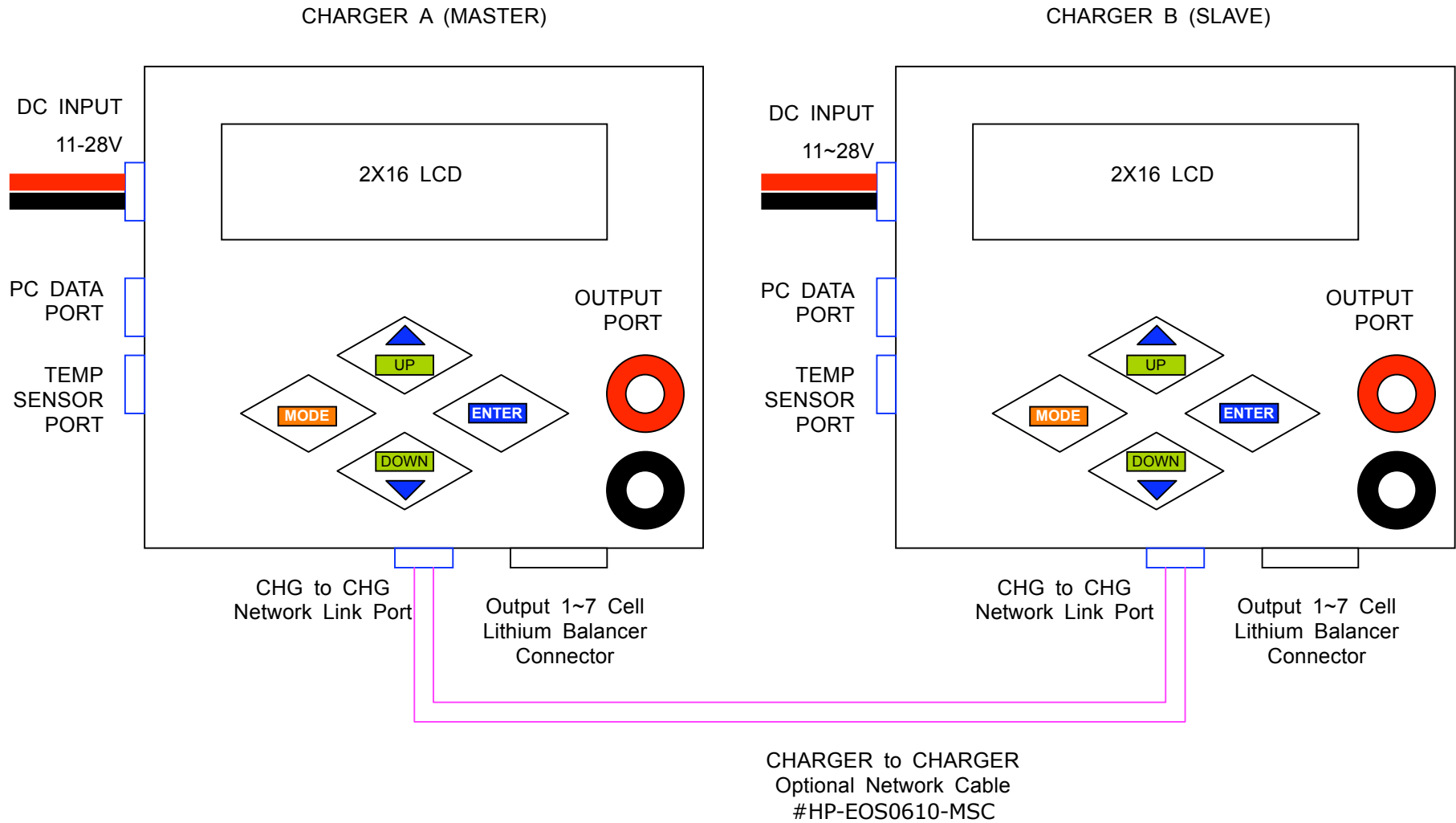

(1) **MAIN MENU FLOW**

(note: whichever charger is used to select SYNC mode becomes the "master")

MASTER

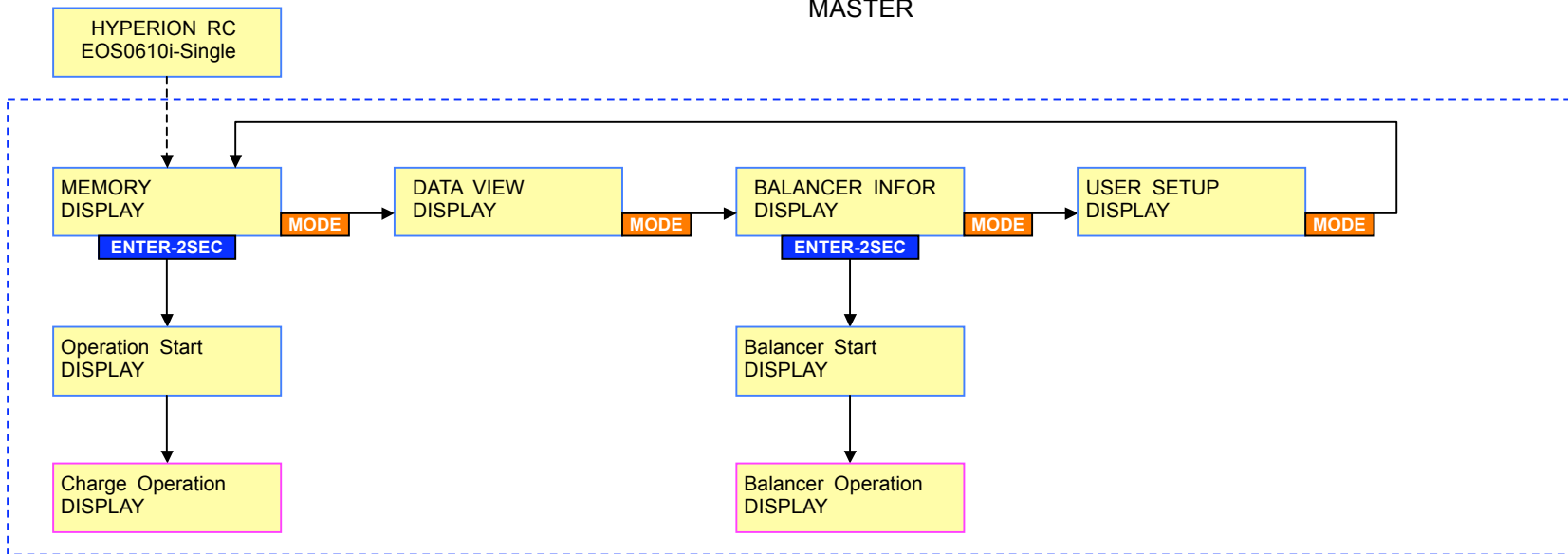

SLAVE

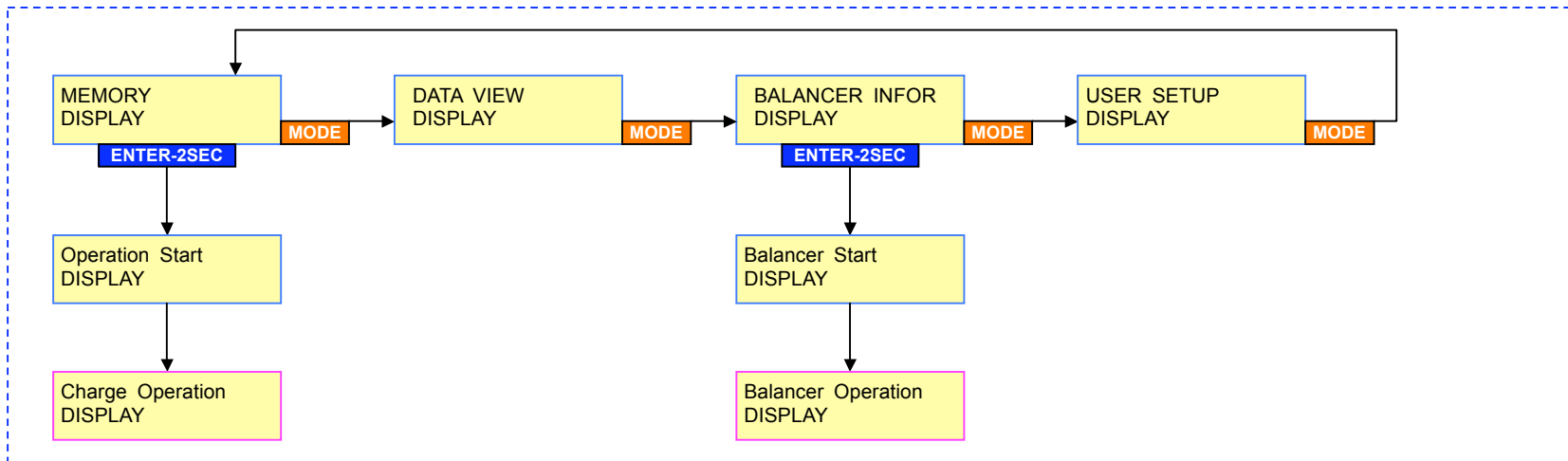

(2) **MEMORY DISPLAY** (settings available per each memory slot, depending on battery type)

LiIo/LiPo/LiFePO4 (a123)

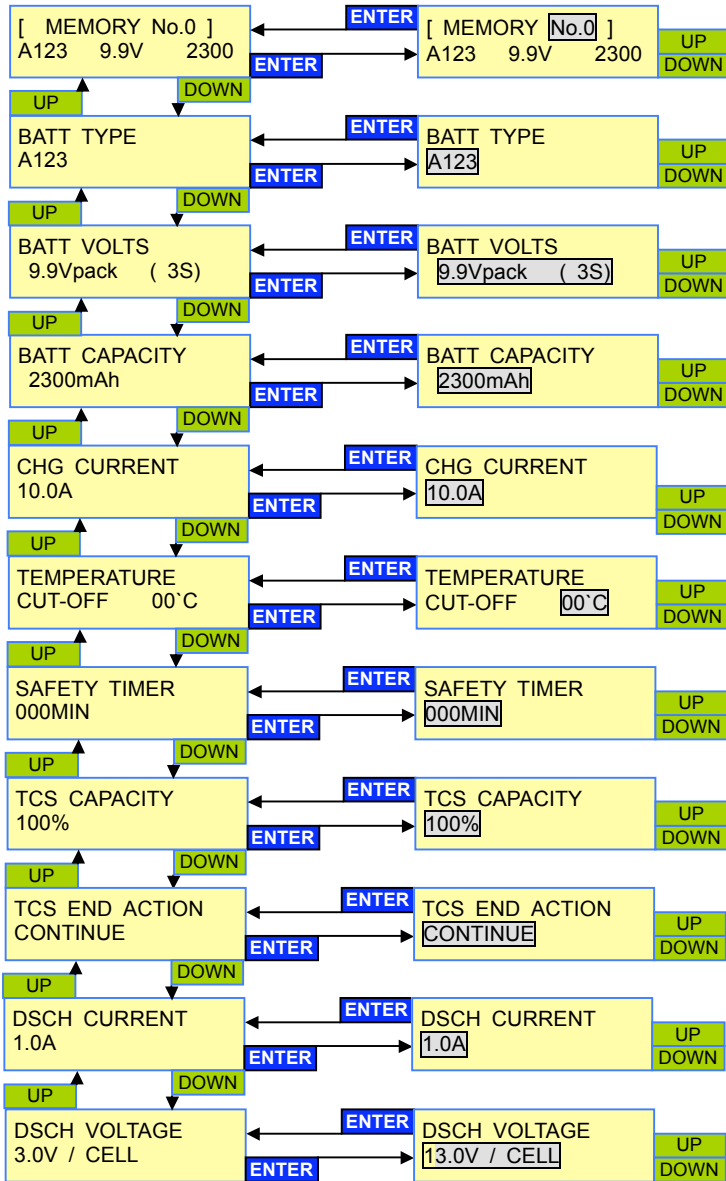

NiCd/NiMH

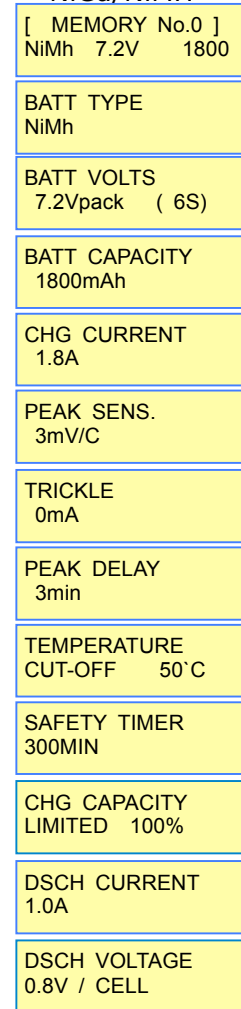

Pb

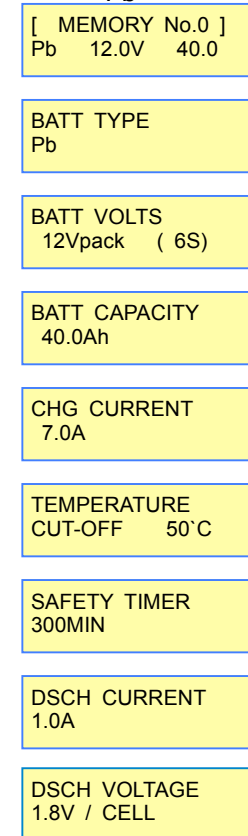

### (3) DATA VIEW DISPLAY

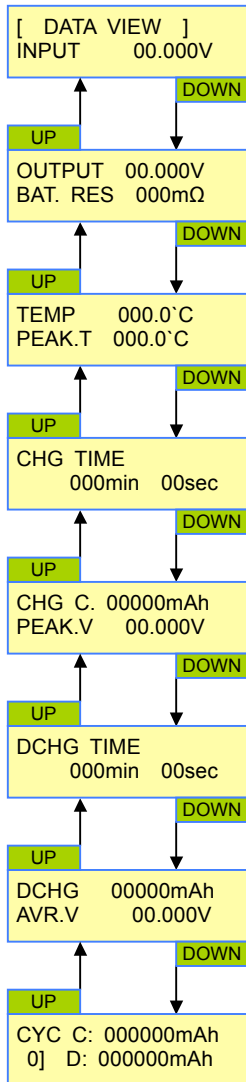

### (4) BALANCE INFORMATION & START DISPLAY

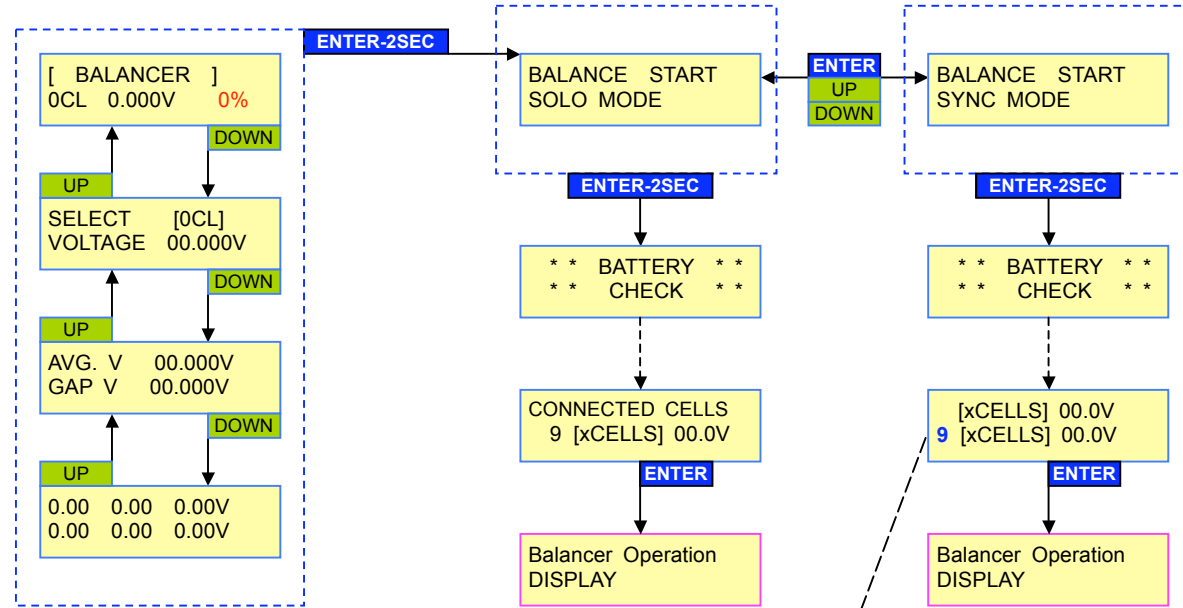

The red 0% above indicates TCS% (capacity)

10-second AUTO Countdown display. Starts charge after 10 seconds if user does not confirm. Only during Balance Charges for Li~ types.

## (5) USER SETUP DISPLAY

### Global Settings

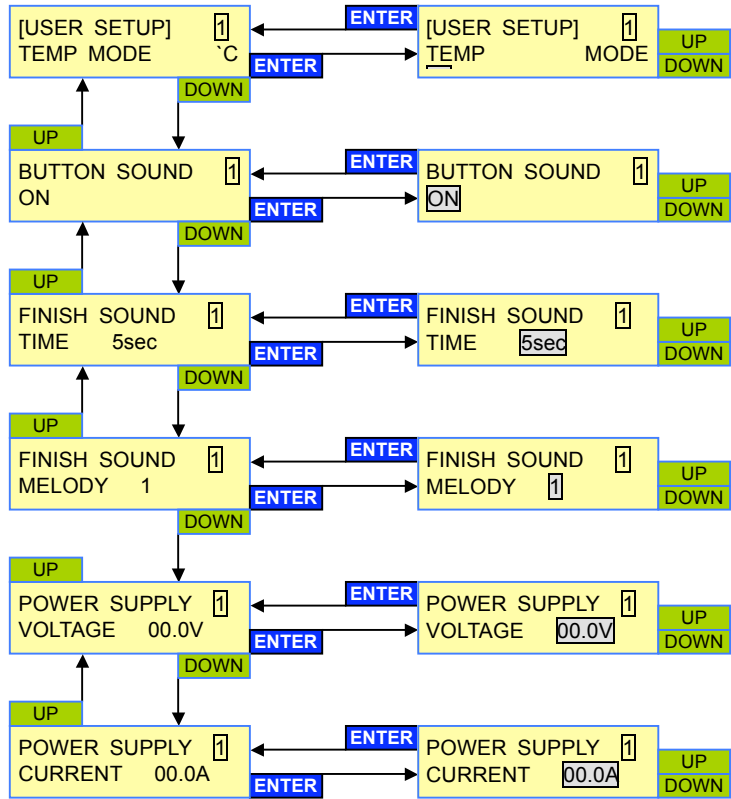

# OPERATIONS START – SETUP & DISPLAY

## (6) NiCd / NiMH BATTERY START

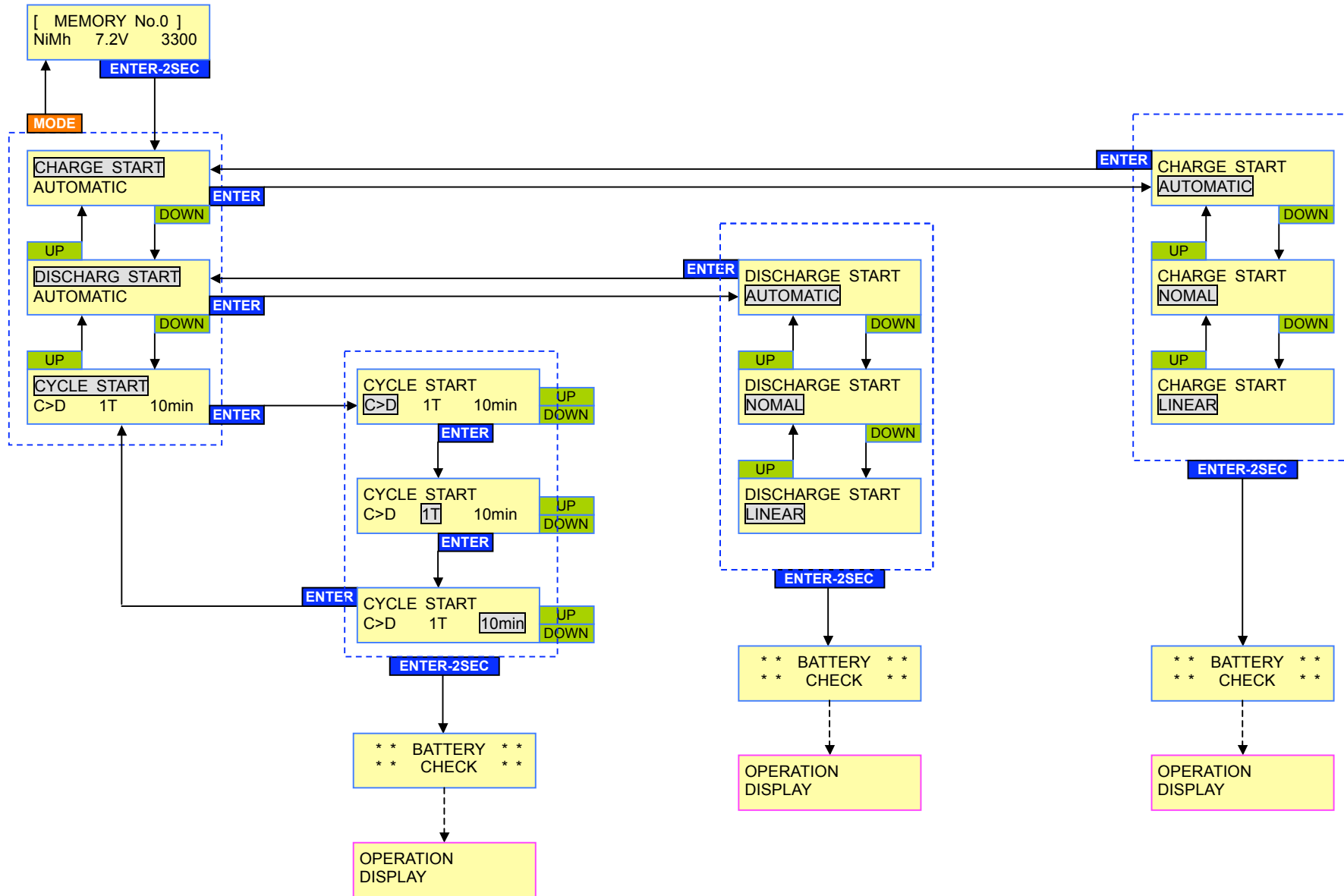

### (7) LiIo / LiPo / A123 BATTERY START

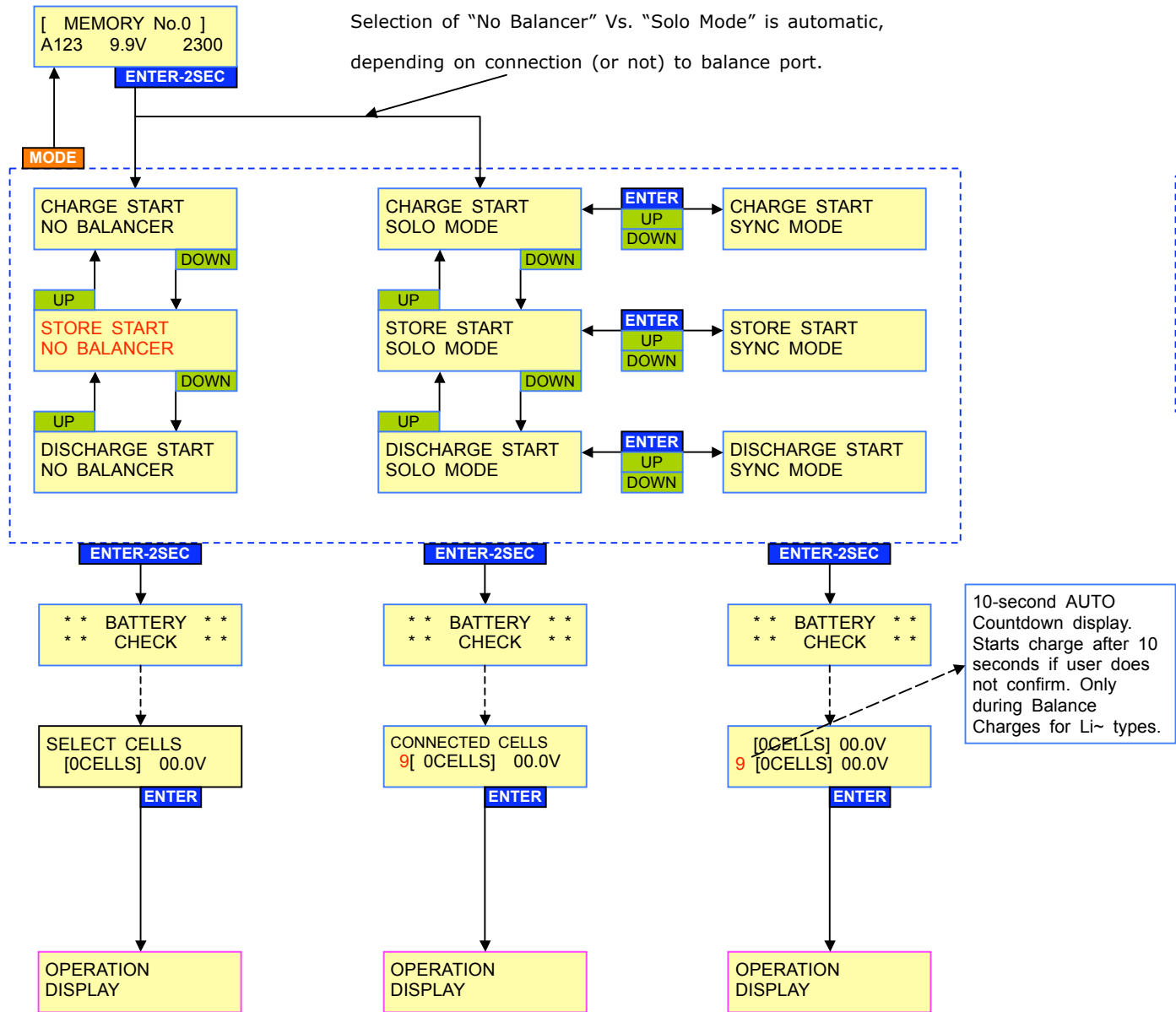

### (8) PB BATTERY START

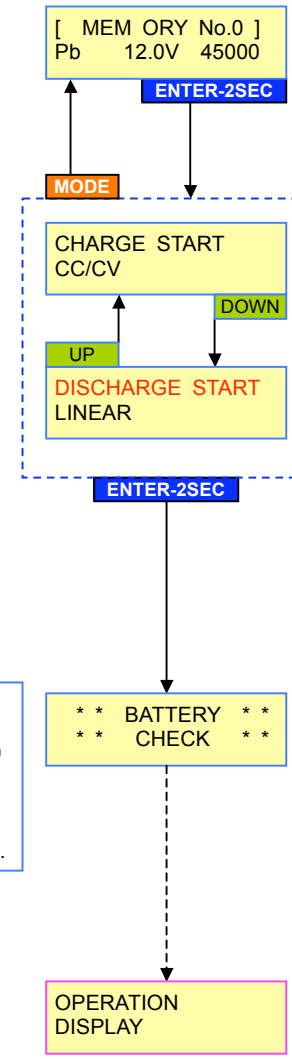

**Note:** STORE Mode only applies to LiIo, LiPo, and LiFePO4(a123) types only. Balancer Connection is **required**. If Balancer is NOT connected OUTPUT BATTERY CONNECT ERROR will

## (9) OPERATION and FINISH DISPLAY

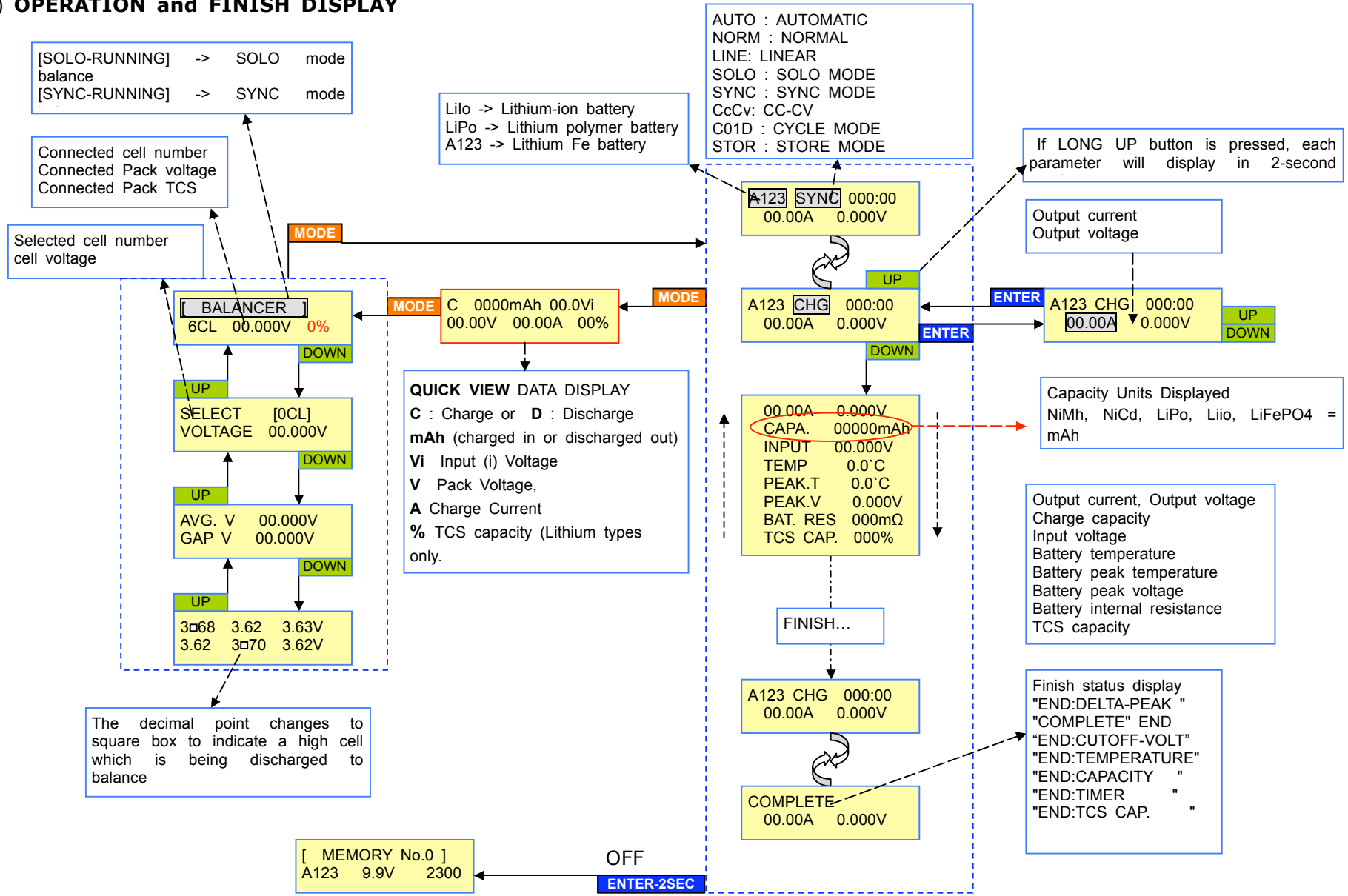

**(10) LiIo / LiPo / LiFePO4 (a123) FINISH DISPLAY**

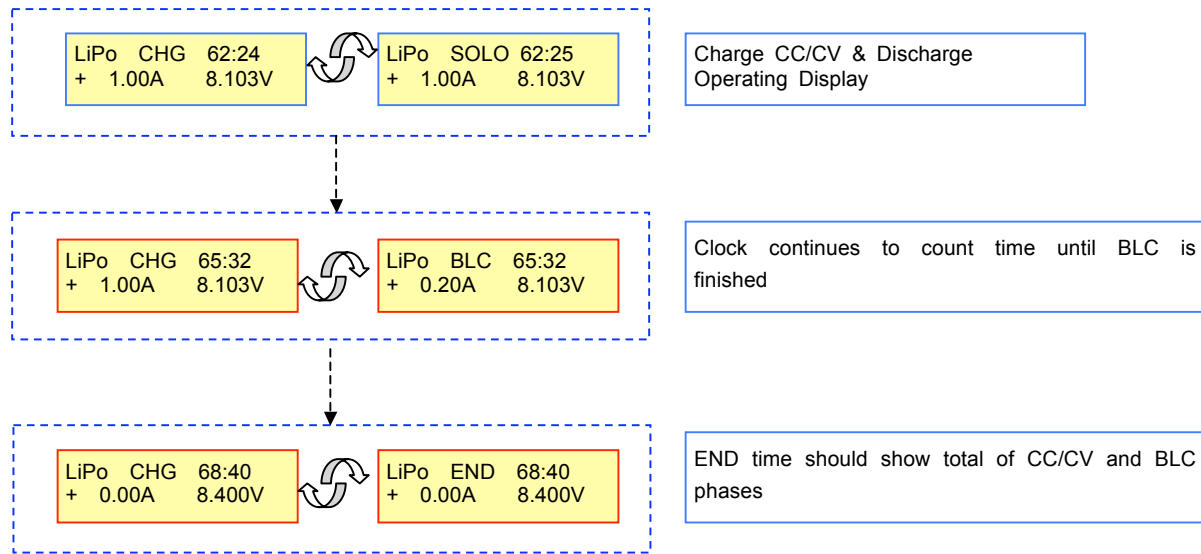

**(11) NiCd/NiMH CYCLE OPERATION DISPLAY**

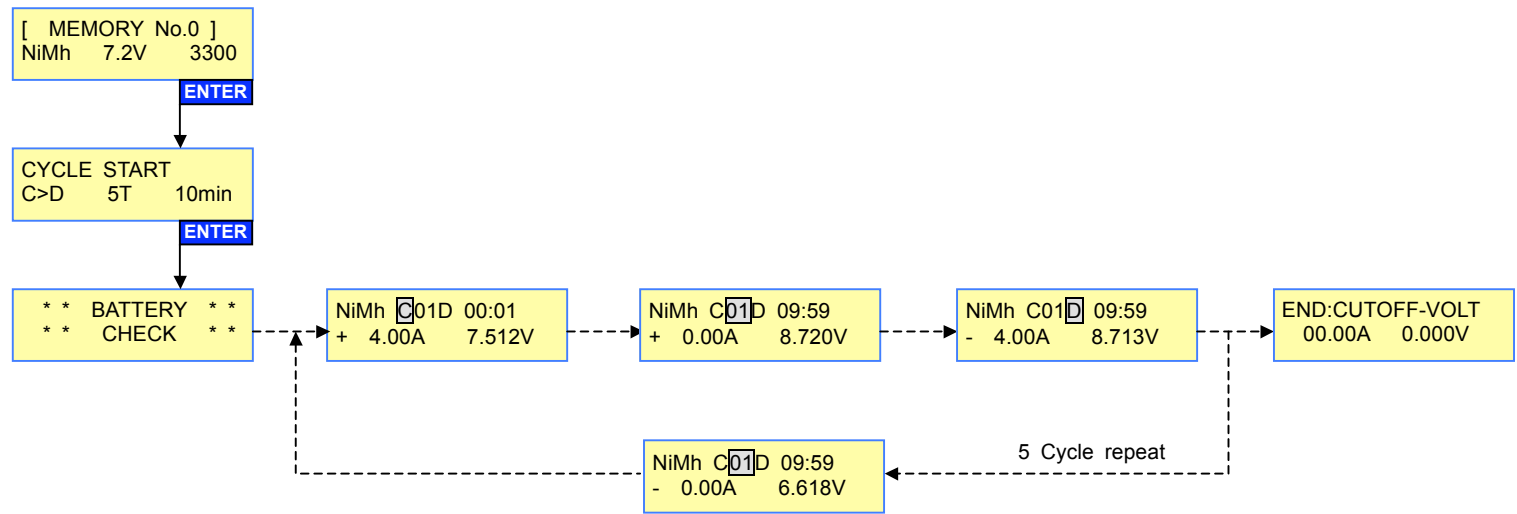

## ERROR MESSAGES

INPUT VOLTAGE ERROR 0.00Vi	When input voltage is below 11.0V or exceeds 28V.
OUTPUT BATTERY CONNECT ERROR	When a battery is not connected to the charger's output
OUTPUT BATTERY REVERSE POLARITY	Output battery is connected to the output in reverse polarity (switch +/-)
OUTPUT BATTERY OPEN CIRCUIT	If the battery becomes disconnected during an operation
OUTPUT CIRCUIT ERROR	The output circuit of the charger has a problem. See troubleshooting above.
OUTPUT VOLTAGE TOO LOW 0.00V	Output voltage is lower than the selected cells or voltages (check battery specs and condition, or reset charger correctly)
OUTPUT VOLTAGE TOO HIGH 0.00V	Output voltage is higher than the selected cells or voltages.
TEMPERATURE SENSOR ERROR	The thermal probe is incorrectly connected, or the probe is damaged.
BATTERY TEMP TOO LOW 0.00V	The temperature of the battery is too low ( below -10°C at idle mode and 0°C during operation, requires probe attached!).
BATTERY TEMP TOO HIGH	Battery temp is too high to be charged! (requires probe attached!)
INTERNAL TEMP TOO HIGH	When the temperature of the charger exceeds 125C. Reduce ambient temp, wait, restart.
BALANCE VOLTAGE CELL(0) TOO HIGH	When the balancing cell voltage is too high. Possible pack damage or connection error.
PAUSE... CHARGER TOO HOT	Charger temperature is too high. Charger will Pause until temp drops
SYNC COMMAND ERROR	Problem with wiring, connectors, or other. Clean and inspect as in Troubleshooting section for OUTPUT
FLAT CHECK	NiCd, NiMH only. Charger cannot detect DeltaV to terminate charge. See Troubleshooting section in text manual.

## HARNESS WIRING FOR HYPERION-COMPATIBLE PACKS

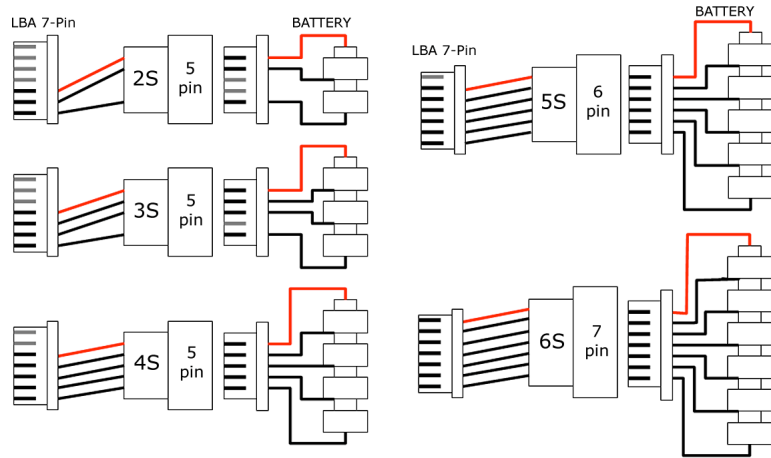

NETII Comes with a HYPERION compatible Multi-adapter to fit 2S to 7S packs (#HP-EOSLBA-7U-B).

Other brand adapters are available as option parts, # **HP-EOSLBA-7Uxx-B** as below:

IF YOUR PACK MAKER IS NOT LISTED BELOW, ASK THE MAKER WHICH BRAND BELOW IT MATCHES.

HP-EOSLBA-7UXH-B	HP-EOSLBA-7U-B	HP-EOSLBA-7UTP-B	HP-EOSLBA-7UEH-B
ALIGN	HYPERION	THUNDER POWER	KOKAM
DUALSKY	POLYQUEST	FLIGHTPOWER-EVO	GRAUPNER
E-FLIGHT	E-TEC	APEX	ROBBE
ELECTRIFLY	POLY RC	VISLERO	NEU
HEXTRONIC	XCITE	DANLIONS	APOGEE
COMMON SENSE V1	MAX AMPS	MPX	VAMPOWER
COMMON SENSE V2	TRUE RC		
ESKY	IMPULSE		
VENOM			
AIR THUNDER			
KONG THUNDER			
GRAYSON POWER			
TENERGY			
DN POWER			
MEGA POWER			
ELECTRIC POWER			
TURBORIX			
ENERGY EC, WOW RC			
IMAX, FULLY MAX			