

HYPERION EOS 0606i

EOS0606i USER'S MANUAL

EOS 0606i Special Features

- *INPUT power DC 11V-15V anywhere
- *Powerful, yet compact and portable with wide support for battery types
- *Integrated Hyperion LBA Balancer for LiPo (3.7v) and LiFe (3.3v) based cells
- *Balance Multi-Adapter for 2S to 6S packs included
- *Charge and Discharge Modes (and Cycling for NiMH and NiCd)
- *Clear and easy-to-read LCD Screen with Warnings common setup errors
- *Packaged in a rugged aluminum case - Long Input leads
- *Hyperion Balance Multi-Connector Included. Option multi-connectors for most common brands are also available (see details end of document)



Specifications

Input voltage range	11.0-15.0V DC
Appropriate battery types and range of series-connected cells	1-14 NiCd – Nickel-Cadmium cells
	1-14 NiMH – Nickel-Metal Hydride cells
	1-6 LiPo – Lithium Polymer cells, 100~6000mAh (3.7V/cell type only)
	1-6 LiFe – Lithium Iron (3.3V/cell types , inc. A123 brand cells / LiFePO4 cells)
	1-6 Lead-Acid cells (2V per cell nominal)
Charge current	0.1A ~ 6.0A MAX, by 100mA steps (50W limit)
Discharge current	0.1A ~ 1.0A MAX, by 10mA steps (5W limit)
Trickle charge current (NiCd, NiMH)	0 ~ 200mA
Charge termination	"Delta V" peak detection for NiCd/NiMH
	"CV/CC" for Lithium and Lead-Acid Batteries
Cycling Modes (NiCd, NiMH)	Charge>Discharge or Discharge>Charge
Display type	2-line, 16 character blue backlit LCD

Safety precautions

- **KEEP CHARGER AWAY FROM CHILDREN AND PETS AT ALL TIMES!**
- **This charger is ONLY for NiCd/NiMH, Lithium (3.7V/cell), A123 (3.3V/cell), and Lead-Acid (2.0V/cell) type cells. DO NOT connect others, such as 3.6V/cell Lithium-Ion, or non-rechargeable batteries!**
- **Always place the charger on a firm, level, and fireproof surface for charging**
- **Do not place the battery or charger on or near flammable materials while in use: Keep away from carpets, cluttered workbenches, etc**
- **Do not exceed cell manufacturer's suggested max charge rates**
- **Do not use automotive type battery chargers to power the charger**
- **Do not leave the charger unattended while charging**
- **Do not allow water, moisture or foreign objects into the charger**
- **Do not open the charger, nor attempt any repair as it is dangerous and will void your warranty**
- **Do not obstruct the air intake holes on the charger**
- **ALWAYS follow correct connection sequence, as given below**
- **CAREFULLY FOLLOW THE BATTERY PACK MAKER'S RECOMMENDATIONS AND SAFETY ADVICE!**
- **USE BALANCER when charging any Lithium based battery pack!!!**

Initial Setup

The EOS 0606i comes with 4mm Bullet Connectors (aka Banana Plugs). Solder your chosen battery-side connector to the bare wire ends of the supplied output harness, taking great care to observe proper polarity. When you create your own output leads use 12swg wire leads for output harness between charger and battery main wires. Harness wire leads should never exceed 20cm in length. Pre-assembled output harnesses are available under Hyperion Part #HP-EOSOUTCORD.

If, after carefully reading the following pages on usage, you have any difficulty using the charger please refer to the final pages for troubleshooting guide and warranty terms. It is well to carefully check your charger before making a return, as problems in setup, cabling, or power supply are much more common than defects in the charger. Chargers returned by the user and later found not defective will only be returned to the user at the user's expense and may incur a service charge.

ALWAYS FOLLOW this connection sequence, and reverse sequence to disconnect:

1) Connect OUTPUT harness 4mm plugs to the sockets located on the right side of the charger.
Take care that the Output Harness RED wire bullet connector goes to the (+) socket, and BLACK wire to (-) .

2a) Connect Charger INPUT alligator clips to an appropriate DC power source:
a) A 12V automobile battery
b) A quality, low-noise DC power supply of 12~15V with 5A+ rating (large batteries may require 10A supply).

3) Set the battery type using the charger configuration buttons.

*The **INC** and **DEC** buttons are used to **Increase** or **Decrease** values, such as Charge Current, Capacity, Cell Count and Voltage. The display depends on the battery type.



*The **INC** and **DEC** buttons are also used to select Charge, Discharge, or Cycle

*The **BATT TYPE** and **ENTER** buttons can be either SHORT pressed or LONG (~1 second) pressed

- Short press **BATT TYPE**: Scroll battery **types**
- Long press **BATT TYPE**: View input/output Data
- Short press **ENTER**: Scroll **settings** for a battery type. Values will blink when selected. Blinking will stop after a few seconds if you do not make a change.
Short press Enter to re-select a setting to change. Short press BATT TYPE to re-select Battery Type, then INC/DEC to change values.
- Long press **ENTER**: START charging (or discharging, or cycling)

Let's start by using a NiMH battery as an example.

When the charger is first connected to input power, it will display the previously used battery configuration. This is especially convenient if you often charge the same type of battery.

1) If **NiMH** is not shown, short push the **BATT TYPE** button to scroll through all battery types. Stop when you reach **NiMH**.

2) Short press the **ENTER** button to select "C", charge rate in Ampere

3) Press INC or DEC buttons to choose the proper rate for your battery pack.

Charging NiCd and NiMH is mostly automatic, and the setup routines are the same for both. You only need to consult the documentation for your battery pack (or ask your dealer) to determine the proper charge current in Ampere (A). If the rate is given in mA, note that 100mA equals 0.1A: so 900mA would be 0.9A, for example.

4) Attach your NiMH battery to the EOS 0606i Output side harness, checking that +/- polarity is correct.

5) Long press **ENTER** button (hold down for about 1~2 seconds) to begin charging

NO BATTERY error – if battery not connected

OPEN CIRCUIT error – if the battery becomes disconnected from the charger after START

REVERSE POLARITY error – if the battery is connected in reverse

In our NiMH charging example above, we pressed the **ENTER** button when "**NiMH**" was blinking, to go directly to charge rate setting. However, if you want to enter **DISCHARGE** or **CYCLE** modes, you can press the **BATT TYPE** button to start **NiMH** blinking, then press **INC/DEC** buttons to scroll through the various modes. Once the mode is settled (like **CYCLE**), short press **ENTER** to start values blinking for editing.

Whenever Lithium battery charging is started with Balancer properly connected, the display will show:

BALANCER CONN. CONNECTED.

If you see instead *BALANCER CONN. NOT CONNECTED*, stop and check your connections carefully, and repair as needed. We strongly recommend lithium balance charging at all times.

Note: The EOS0606i does not support charging of legacy 3.6v Lithium Ion cell types.

Never attempt to charge these cells, under any circumstances, using this charger.

IMPORTANT NOTE: Lithium polymer cell types should be charged/discharged while connected to Balancer. Charging/Discharging without balancer connected greatly increases the chance of accident. The larger the pack is, or higher the cell count, the more critical it is that Balancer be used. Only very small LIPO packs in 2S or 3S configuration (such as 300mAh) should ever be charged without balancer (these often do not have taps to save weight).

LiFePO4 (A123) packs should ALWAYS use balancer, due to the nature of their charge process.

In all cases, charge/discharge in a fireproof environment with persons in attendance!!

LITHIUM POLYMER MODE (for 3.7V/cell types only!)

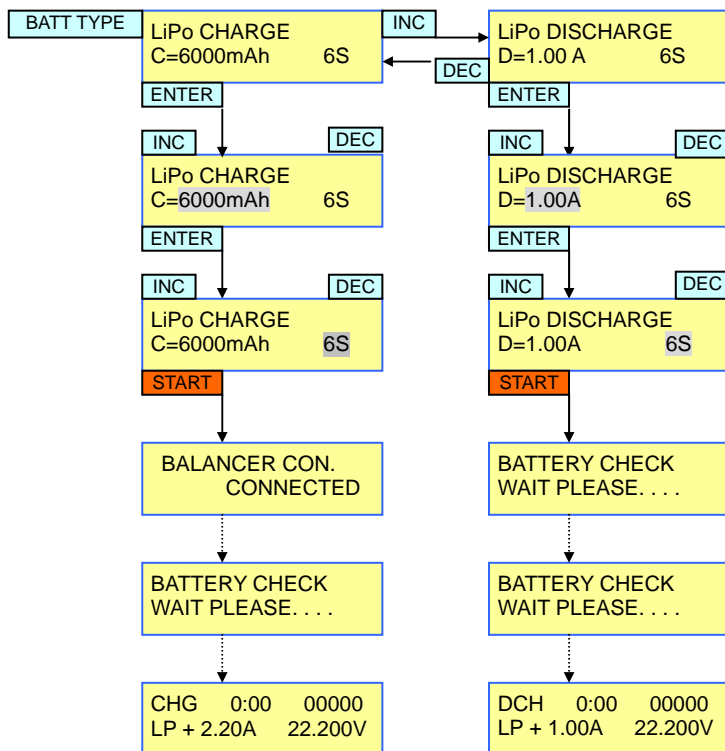

Number of LiPo Cells Wired in Series (Pack Voltage)					
1S	2S	3S	4S	5S	6S
3.7V	7.4V	11.1V	14.8V	18.5V	22.2V

Setting LiPo battery capacity

LiPo CHARGE
C=6000mAh 6S

Adjust and set the desired battery capacity from 100mAh to 6000mAh with INC & DEC buttons (50mAh per step). Press the ENTER button to confirm setting. Charge rate is set on the basis of selected capacity, at 1C rate. Example: Li-Po cell of 1500mAh capacity: 1C = 1500mAh (= 1.5A). If your battery is larger than 6000mAh, you can charge it at the 6000mAh setting, but it will just take longer to finish charging.

LiPo CHARGE
C=6000mAh 6S

Setting Battery Voltage / Number of Cells in Series for LiPo battery packs

Select the total battery voltage to be charged with ENTER, INC & DEC buttons. The charger knows the pack's voltage both from the balancer connector and the cell count e.g. '6S'

NOTE: The EOS Series chargers have intelligent detection routines to help you avoid making mistakes, and LOW or HIGH VOLTAGE errors are displayed if battery voltage does not match your setting. HOWEVER, under some circumstances, especially with over-discharged or damaged batteries, the safeguard could fail. *Therefore, be absolutely sure that you have correctly set pack voltage correctly before charging, every time!*

LiPo DISCHARGE
D=1.00 A 6S

Setting discharge parameters

Adjust to the desired discharge current from 0.10A to 1.00A (0.01A per step) with INC & DEC button. Press the ENTER button to confirm setting. Set pack voltage, 1S~6S as in charging example above. Autocut occurs automatically at 3.0V per cell.

LiFe MODE [LiFePO4, A123]

The LiFe charge/discharge modes are intended for cells with 3.3V nominal, with Lithium Phosphate chemistry. The LiFe (LiFePO4 charge/discharge modes are intended for cells with 3.3V nominal produced by A123 Company, or other-brand LiFePO4 cells which are recognized to be of good quality from well-known makers. Choose LiFe for *BATT TYPE*, for charging such cells. The LiFe charge mode MAY work with "no brand" LiFePO4 cells having 3.3V nominal voltage, but Hyperion has found some "knock off copy" cells in the market of very questionable quality. **Customers who use A123 mode (LiFePO4 mode) to charge such off-brand cells assume all risk. In no case does Hyperion HK Ltd. Accept liability due to the failure of the cell(s) itself during charging or discharging.**

Due to the nature of A123/LiFePO4 cells (wide divergence in cell voltages during charging) and due to the high rates at which some of these cells – such as A123 brand – can be charged, one **MUST ALWAYS properly use the cell balancer function** whenever charging in LiFe Mode; failure to do so will result in poor pack performance at best, and damage to cells at worst. **Customers who charge in LiFe mode without balancer connected assume all risk of charger and battery failure!**

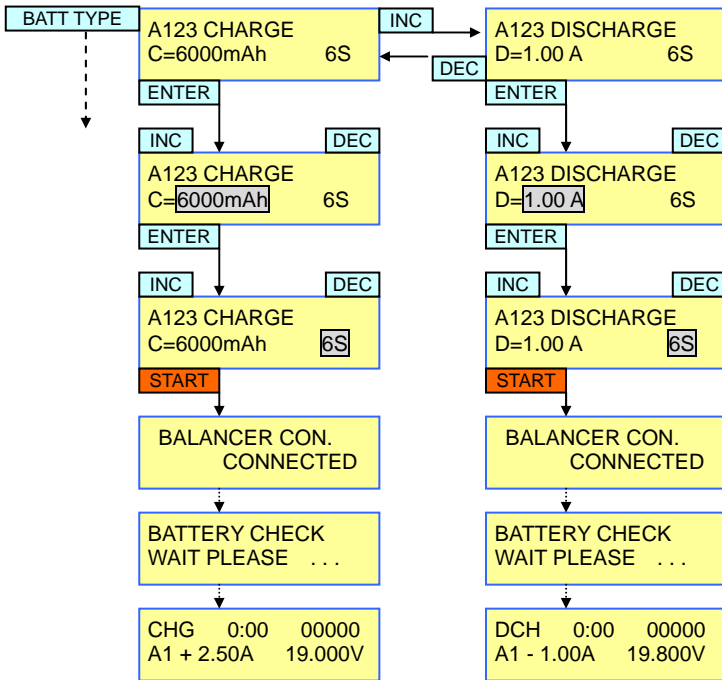

Number of LiFe Cells Wired in Series (Pack Voltage)					
1S	2S	3S	4S	5S	6S
3.3V	6.6V	9.9V	13.2V	16.5V	19.8V

A123 CHARGE
C=6000mAh 6S

A123 CHARGE
C=6000mAh 6S

A123 DISCHARGE
D=1.00 A 6S

Setting charge current

The EOS 0606i will charge the battery at a 1C rate from the capacity you tell it. It is possible to charge at higher than 1C but the user accepts all responsibility.

Setting battery charge voltages for A123/LiFe battery pack

Set the number of cells in series that make up your battery pack. This in turn, with the correct cell type, tells the charger the packs voltage. Used with the balancer makes for safer charging.

Setting discharge current

Press Enter to find and adjust the desired discharge current from 0.10A to 1.00A (0.01A per step) with the INC & DEC buttons. Press the ENTER button to confirm the setting.

NiCd / NiMH MODES (NiMH mode is the same as below, except Mode shows 'NiMH')

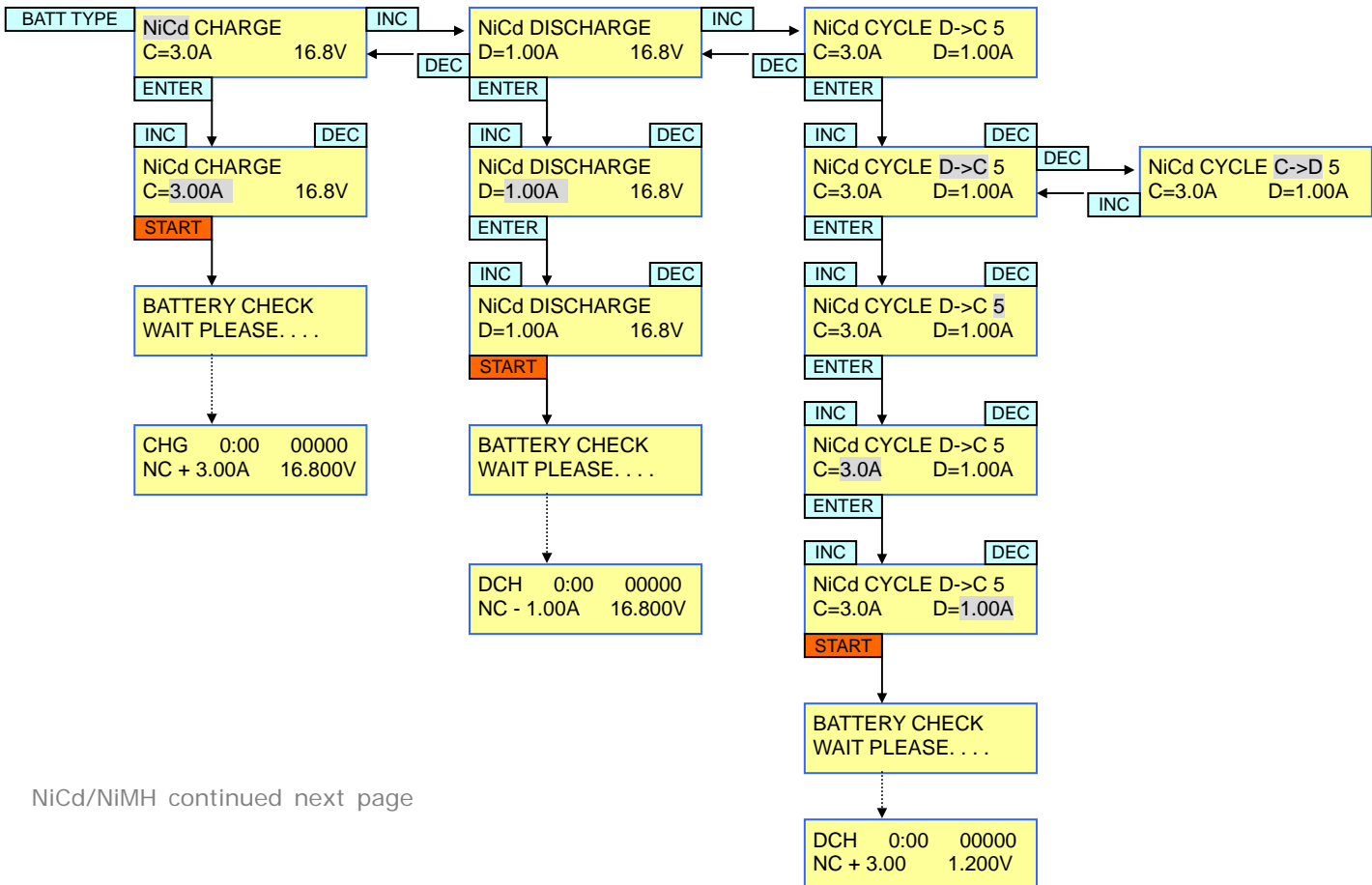

NiCd CHARGE
C=3.00A 16.8V

NiCd DISCHARGE
D=1.00A 16.8V

NiCd DISCHARGE
D=1.00A 16.8V

NiCd CYCLE C->D 5
C=3.0A D=1.00A

Setting charge current

Adjust and find the desired charge current which ranges from 0.1A to 6.0A with INC & DEC buttons. Press the ENTER button to confirm setting.

Setting discharge current

Adjust and find the desired discharge current, ranging from 0.1A to 1A, with INC & DEC buttons. Press the ENTER button to confirm setting. Auto-limit may reduce the current limiting the discharge power to 5W.

Setting discharge cutoff voltage

This is the voltage that the charger should stop discharging the battery.

Adjust and find total discharge cutoff voltages to be discharged from 0.1V to 16.8V with INC & DEC buttons. Press the ENTER button to confirm setting.

Setting cycle

This is to set cycling with two options (Charge to Discharge / Discharge to Charge). Set cycling with INC & DEC buttons, and press the ENTER button to confirm setting.

Pb MODE (lead-acid battery)

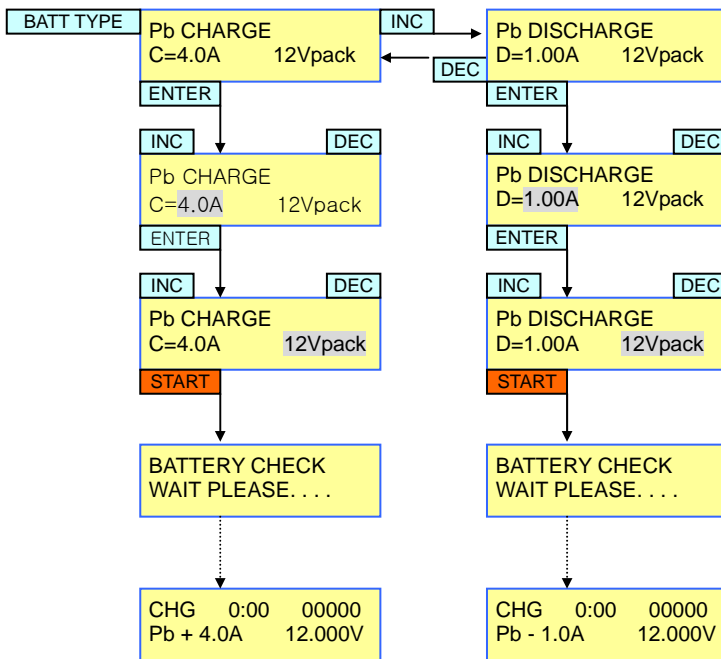

Pb CHARGE
C=4.0A 12Vpack

Setting charge current

Adjust and find the desired charge current which ranges from 0.1A to 6.0A with INC & DEC buttons. Press the ENTER button to confirm setting.

Pb CHARGE
C=6.0A 12Vpack

Setting total battery voltage for Lead-Acid Battery

Select the proper total battery voltage to be charged or discharged with INC & DEC buttons – 2V, 4V, 6V, 8V, 10V, and 12V [2V per cell types only]

Pb DISCHARGE
D=1.00A 12Vpack

Setting discharge current

Adjust and find the desired discharge current from 0.10A to 1.00A (0.01A per step) with INC & DEC button. Press the ENTER button to confirm setting.

Displays during Charge, Discharge, and Cycle

Note that exact display may depend on type of battery and connection. For example, Lithium types when connected to a balancer will alternately show CHG / BLC at top left while charging, and CHG / BLC / END when finished charging. Also note that after charging the EOS0606i may apply maintenance trickle charge or balance discharge as needed until disconnected.

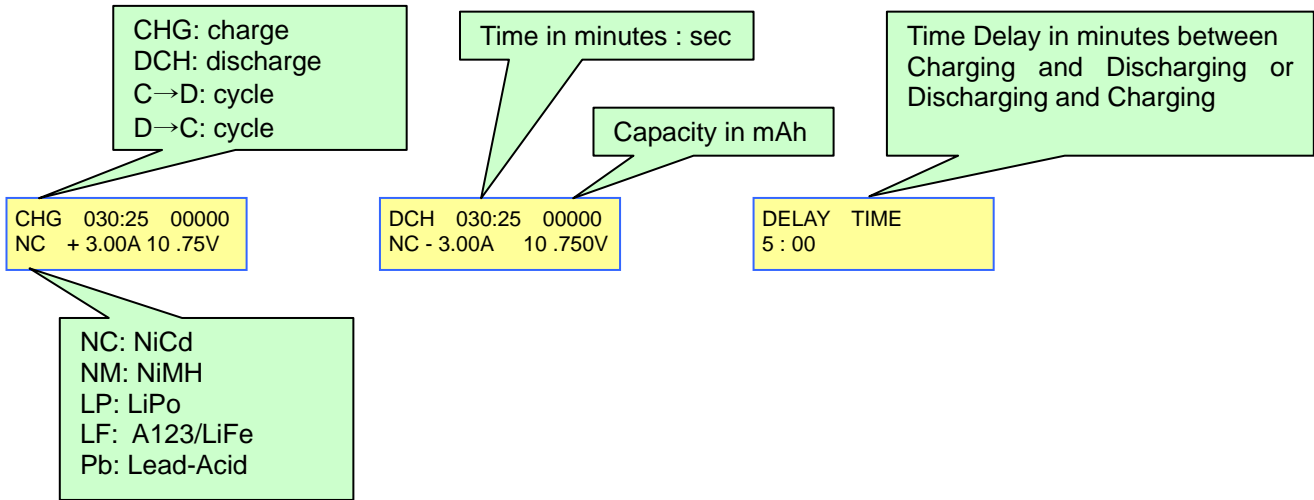

Completion Display

When the Enter button is pressed, charge or discharge will be stopped.

```
END 030:00 00000
NC 100mA 10.75V
```

In order to move back to the main display, press the Enter button.

Data Display – Keys

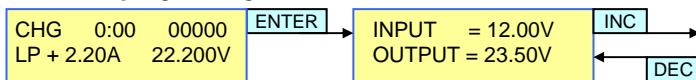

Press BATT TYPE during charging or discharging to view the data display menu.

Use INC and DEC to scroll through the data screens.

Pressing BATT TYPE again will return you to the charge/discharge screen.

Data Display – Screens (Example: During a Balancer-Connected Lithium Charge)

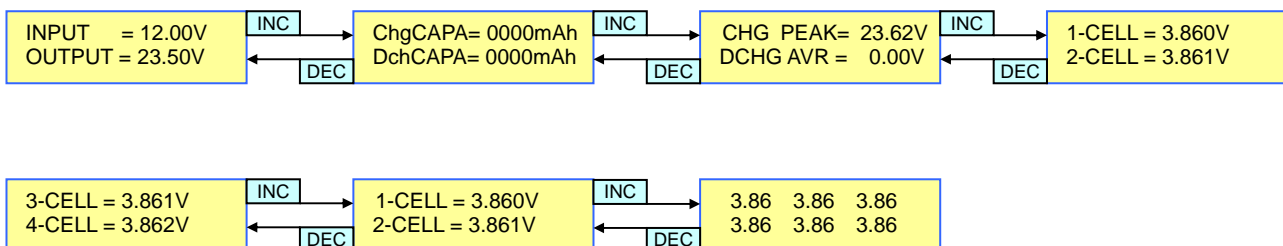

TROUBLESHOOTING

(1) Check again that the battery you are trying to charge and the settings on the EOS 0606i match. Battery type (such as NiMH or Lithium), battery capacity, number of cells (charge voltage), and charge rate must all be correct.

(2) Check that the input cable and output cables:

*Have proper connectors in good condition

*Are not frayed, worn, cut, or damaged

*Are the proper gauge (2.5mm, 14swg or higher)

*Are proper length – 20cm (8”) on output side

(3) Attach the charger input connectors to a 12V automotive battery that is in good condition and fully charged. Wiggle the Terminal clips into the battery posts to insure that you have a good connection. Try the AC input if failing while using DC.

(4) Try another battery for charging. If your RC battery is in poor condition, **over discharged**, or in some other way

defective the charger may correctly refuse to charge it based on safety algorithms.

(5) Try another RC battery type. For example switch to a NiMH battery if you are failing to charge Lithium types. Success with one type but failure with another generally indicates that the charger is working properly. The failing battery type is almost certainly in poor condition, then, or you have improperly set the charger for it.

(6) Contact your dealer with full details and description of the problem, including the type of input power source, RC battery type and cell count, and history of the charger – specifically, has the charger been working properly before, or failing from new condition?

ERROR MESSAGES	
INPUT VOLTAGE ERROR	Input voltage is below 11.0V or exceeds 15.0V
NO BATTERY	Battery not detected
OUTPUT BATT REVERSE POLARITY	Battery is connected in reverse polarity to Output leads
OUTPUT CIRCUIT PROBLEM	Non-Specific Circuit error. Check battery condition
CHECK BATT OPEN CIRCUIT	Battery disconnected during charging
CHECK BATT OVER VOLTAGE	Battery voltage too high to match charger settings
CHECK BATT LOW VOLTAGE	Battery voltage too low to match charger settings
BALANCER VOLTAGE TOO HIGH	If voltage per cell is too high during balancing, this message may appear.
BALANCER VOLTAGE TOO LOW	If cell's voltage falls too low during balancing, this message may appear
DON'T CHARGE Lixx WITH THIS MODE	A Lithium pack is connected by balancer, but NiCd/NiMH/Pb mode is selected for charging

Note: If the incorrect number of cells is selected for a lithium type battery, and charging is begun, the charger may give error immediately and stop charging. In some cases, however, the charger will begin charging at the (lower) voltage it sees as correct, and watch all cells to confirm the incorrect setting. For example, if you connect a 3S pack but set the charger for 4S by mistake, the charger may begin by charging at 3S voltage level, and watch all cells. When the mistake is confirmed, the charger will give error and terminate. This is normal and correct behavior.

BALANCE MULTI-CONNECTORS

Hyperion Balance Multi-Connectors for most common lithium pack brands are available from your dealer: #HP-EOSLBA-26xx
Applications list below may be subject to change, depending on maker decisions outside our control. If your brand is NOT listed, email your battery maker to ask them WHICH OF THE BRANDS BELOW they are compatible with.

HP: fit HYPERION, POLYQUEST, PolyQ, ETEC, and some other brand packs.

EH: fit KOKAM, GRAUPNER and ROBBE

XH: fit ALIGN and DUALSKY packs

TP: fit recent THUNDERPOWER and all FLIGHTPOWER* packs from 2S to 6S.

Tech Note*: Due to the wiring arrangement on some Thunderpower and FlightPower 4S packs only, the 4S packs may need the 6th wire removed in order to function properly with HP-EOSLBA-26TP MultiAdapter for 4S charging.
 SEE DIAGRAM at <http://media.hyperion.hk/dn/eos/eoslba26/EOSLBA26TP-FP4Smod.gif>

WARRANTY

HYPERION Chargers are guaranteed to be free from defects in materials and workmanship for a period of one calendar year from date of purchase. Your selling dealer is your first point of contact for warranty issues. Return postage costs are the responsibility of the user in all cases. Submit copy of original receipt with the return.

Damage due physical shock (dropping on the floor, etc), inappropriate power supply (automotive battery charger, etc!), water, moisture, and humidity are specifically NOT covered by warranty. It is well to carefully check your charger before making a return, as problems in setup, cabling, or power supply are much more common than defects in the charger.

Enjoy the Power!

The Hyperion Team